

ESAB CaB 460M

A Modularised Column and Boom for customised weld mechanization

Productivity

In today's industrial development, the rate of productivity has been brought more and more into focus as a decisive parameter for raised profitability.

This requires individually adapted production solutions, flexible enough to conveniently switch over, without extensive rebuilding, between a variety of applications. In close co-operation with the welding industry ESAB has created an application oriented Column and boom range with integrated modular functions in order to meet our customers' demands for purposeful solutions on a competitive market.

Stability and reliability

CaB 460M has a stable and robust design of the profiles and saddle providing large working ranges and heavy load capacity with ample safety margins for reliable operations. Different types of foundations are available; rail carriage, concrete stand or steel plate – to fit any need. The lift drive has a reliable safety factor and is supplied with a security device which, regardless of boom position, immediately locks the boom to prevent unwanted descent in the event of a breakdown. Positioning of the horizontal boom can easily be carried out both in the vertical and horizontal direction. An even and stable welding speed is secured by the rack and pinion drive. The control system has been designed with totally integrated functions; welding head manipulation and operation of the column and boom – of course remote controlled.



CaB 460M



Individual solutions

When dressing up the naked column and boom into a complete welding solution, the optional combinations are almost unlimited.

In order to facilitate the selection process to result in a specification based on customer's application, there is a computer aided configuration system available.

Together with the ESAB representative the customer is able to build up his welding solution, i.e. a specification of the modular components to be assembled and installed at the customer's workshop in a most convenient manner.

For all modular components applicable for this column and boom, kindly refer to our range of leaflets available from our representative.

Technical data, Column

Effective working range (m)	4	5	6
Boom height A (max mm) using movable carriage (min mm)	4950 950	5950 950	6950 950
Boom height B (max mm) using concrete stand (min mm)	4845 845	5845 845	6845 845
Boom height C (max mm) using stationary foot plate (min mm)	4510 510	5510 510	6510 510
Total height D (mm) using movable carriage	6275	7275	8275
Total height E (mm) using concrete stand	6170	7170	8170
Total height F (max mm) using stationary foot plate	5835	6835	7835
Lifting speed (m/min)	2.0	2.0	2.0
Total load on column platform (max kg)	1500	1500	1500
Total weight incl. saddle (kg)	1600	1740	1880

Technical data, Boom

Effective working range (m)	4	5	6
Extension G (max mm) (min mm)	4715 715	5715 715	6715 715
Permissible loads			
-total (max kg)	1100	1050	1000
-one end (max kg)	550	450	350
Cross-sectional diameter H (mm)	630	630	630
Welding speed (m/min)	0.1-2.0	0.1-2.0	0.1-2.0
Transport speed (m/min)	2.0	2.0	2.0
Total weight incl. cables (kg)	510	590	670

Technical data, Rail carriage

Track width L , inside to inside (mm)	1730
Width x length (mm)	2100x2380
Height I (mm)	485
Welding speed (m/min)	0.1-2.0
Transport speed (m/min)	2.0
Total weight (kg)	2860

Technical data, Concrete stand

Width x length (mm)	2100x2410
Height J (mm)	380
Total weight (kg)	2900

Technical data, Foot plate

Width x length (mm)	1600x1600
Height K (mm)	40
Total weight (kg)	505

Ordering information

Working range	Rail carriage Part no.	Stationary Part no.	Foot plate mounted Part No.
4x4	0809 600 886	0809 600 906	0809 600 926
5x5	0809 600 888	0809 600 908	0809 600 928
6x6	0809 600 890	0809 600 910	0809 600 930

Prepared for camera:

4x4	0809 600 946	0809 600 966	0809 600 986
5x5	0809 600 948	0809 600 968	0809 600 988
6x6	0809 600 950	0809 600 970	0809 600 990

Other combinations of working ranges and foundations on request.

Adapted modules: Motorised rotation, pneumatic brake, shift function boom - slide travel, warning light, 4 WD, operator chair, ladder for column hoist inspection.

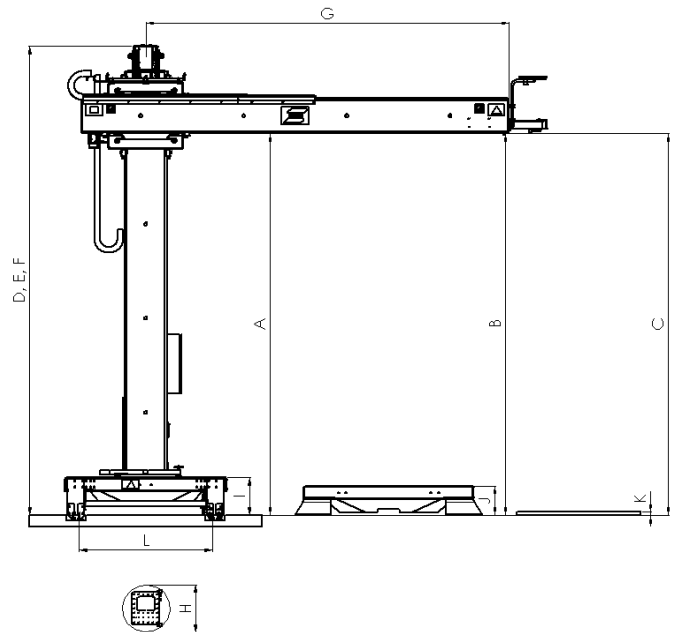

There are that many alternatives and options available to choose among in order to compose your welding station as per your individual need. To facilitate this composition we have created a configurator tool by means of which you together with our representative conveniently can procure the correct tailor-made station.

Make a choice of:

- Foundations:** Concrete carriage, Concrete stand, Steel plate
 - Track widths:** 1600-2000 mm
 - Drive units:** 2 or 4 Wheel Drive
 - Tacho controls:** Rail carriage, boom and wire feed
 - Joint trackings:** PAV or GMH
 - Welding heads:** A2S, A6S, A6S Tandem, twin or single, SAW or GMAW
 - Power sources:** LAF 631, TAF 801, LAF 1001, LAF/TAF 1251, LAF 1601 including welding cables 95 mm² or 120 mm²
 - Platform:** Single, double and operator platform
 - Wire equipments:** 1-2x30 kg front mounted
1-4x30 kg or 1-4x100 kg rear mounted
 - Flux handlings:** OPC Super, FFRS Super, FFRS 1200 or FFRS 3000E
Air dryer CRE, TPC 75 with or without heaters and level indicator, Tedak filter
 - Camera systems:** SAW or GMAW
- and more...



ESAB AB
Welding Equipment
 SE-695 81 LAXÅ SWEDEN
 Phone: +46 584 81000
 Fax: +46 584 411721
 E-mail: info@esab.se
www.esab.com

