

NUMERY ZAMÓWIENIOWE

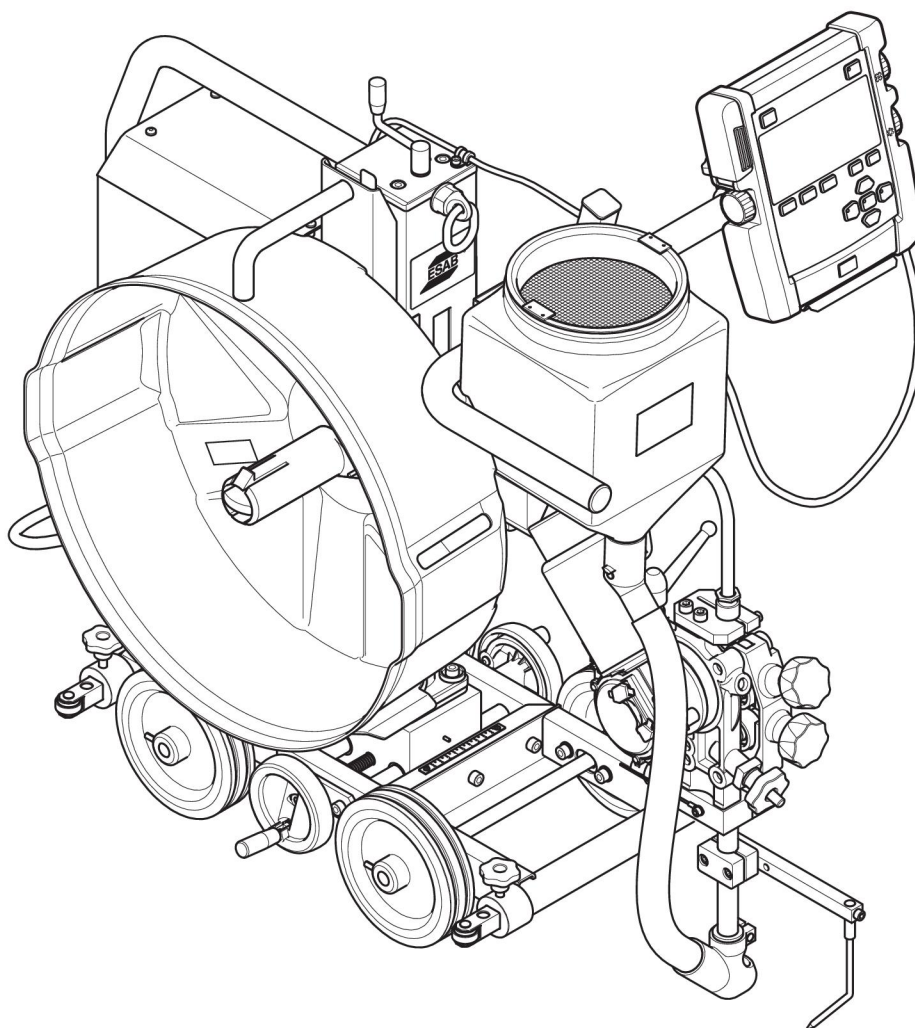

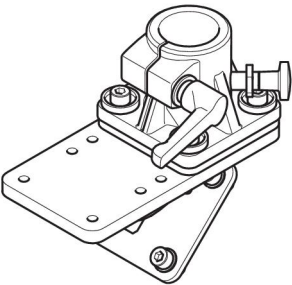
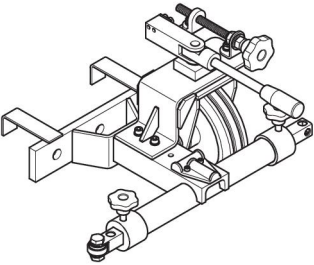
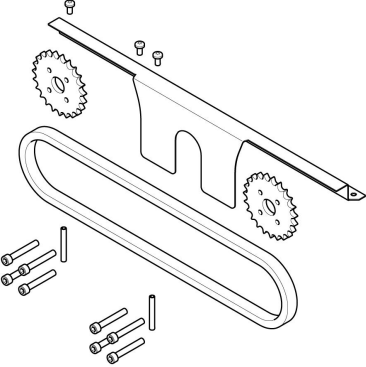
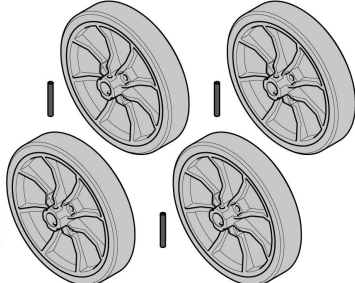
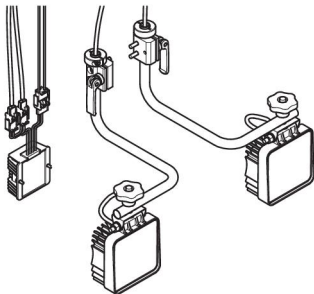

Ordering number	Denomination	Type	Notes
0904 200 880	Welding tractor	Versotrac EWT 1000 including welding head EWH 600 / EWH 1000, bobbin holder and control unit EAC 10.	Feed roller and contact tip not included.
0463 627 *	Instruction manual	EWH 600 / EWH 1000 welding head	
0463 612 *	Instruction manual	EAC 10 control panel	Describes software functions.
0463 609 *	Instruction manual	EAC 10 control unit	
0463 614 001	Spare parts list		

Dokumentacja techniczna jest dostępna w internecie pod adresem www.esab.com

ACCESSORIES

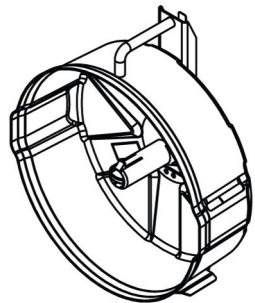
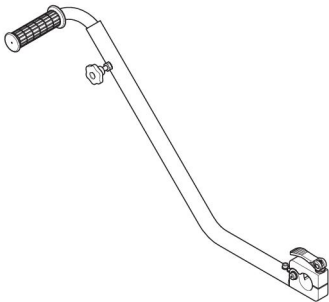
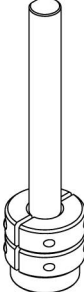
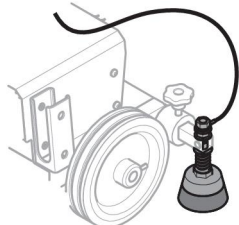
EWT 1000		
0904 586 880	Flat fillet welding kit	
0904 557 880	Three wheeler module	
0910 053 880	4 wheel drive kit Early version of tractors have old version of wheels that are not compatible with the 4 wheel drive kit. In this case both kit and new wheels are needed. Item 0910 531 880 shows the new version of wheels, that compatible with the 4 wheel drive kit.	
0910 531 880	Wheel kit	
0904 273 880	LED lamp kit, 27 W, 12/24 V	

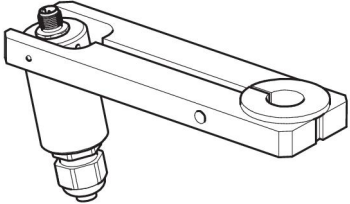
EWT 1000		
0908 520 880	Bobbin holder	
0904 537 880	Steering handle	
0446 151 880	Idling roller (1 piece)	
0443 682 881	V-wheeltrack steel (4 pcs)	
0443 682 880	V-wheeltrack steel (1 piece)	
0332 947 880	Bracket suction	
0904 223 880	Work piece voltage reference brush	
0413 542 880	Guide wheel bogey. For V-joints, used for joint tracking, for fitting on the contact tube.	
0415 857 002	Heat resistant wheel (1 piece), 250 °C (482 °F)	
0154 203 880	Guide rail with magnets, 3 m (9.8 ft). Several lengths of guide rail can be used.	

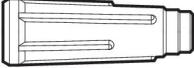
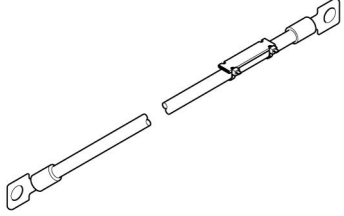
EWH 1000		
0821 440 984	Laser lamp kit, 0.5 m (1 ft 7.7 in.) cable	
0160 360 882	OKC connector Male, 70-120 mm²	
0160 361 882	OKC connector Female, 70-120 mm²	
Welding cable with OKC		
0446 134 880	95 mm ² , 15 m (49 ft)	
0446 134 881	95 mm ² , 25 m (82 ft)	
0446 134 882	95 mm ² , 35 m (115 ft)	
0446 134 883	95 mm ² , 50 m (164 ft)	
0446 134 884	95 mm ² , 75 m (246 ft)	
0446 134 885	95 mm ² , 100 m (328 ft)	
0446 134 890	120 mm ² , 15 m (49 ft)	
0446 134 891	120 mm ² , 25 m (82 ft)	
0446 134 892	120 mm ² , 35 m (115 ft)	
0446 134 893	120 mm ² , 50 m (164 ft)	
0446 134 894	120 mm ² , 75 m (246 ft)	
0446 134 895	120 mm ² , 100 m (328 ft)	
0810 093 880	Flexible arm	
0148 140 880	Flux recovery unit OPC	
0413 315 881	Flux hopper of silumin alloy	
0145 221 881	Concentric flux feeding funnel	
Contact tube		
0413 510 001	260 mm (10.24 in.)	
0413 510 002	190 mm (7.48 in.)	
0413 510 003	100 mm (3.94 in.)	
0413 510 004	500 mm (1 ft 7.7 in.)	
0413 511 001	Contact tube, bent	

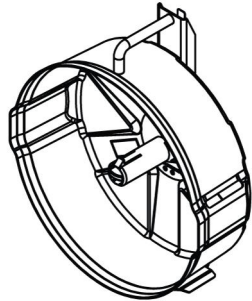
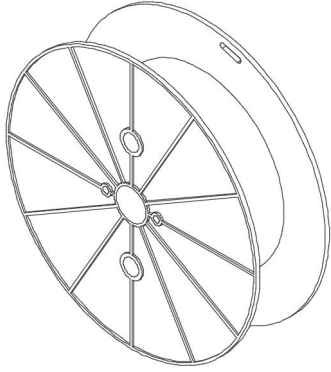
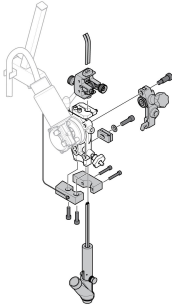

ACCESSORIES

0908 520 880	Bobbin holder	
0153 872 880	Wire reel, plastic, 30 kg	
0449 125 880	Wire reel, steel, flexible width	
0671 164 080	Wire reel, steel Ø 220 mm	
0446 110 880	Single to twin conversion kit	

EAC 10

Control cable EAC 10 - digital power source

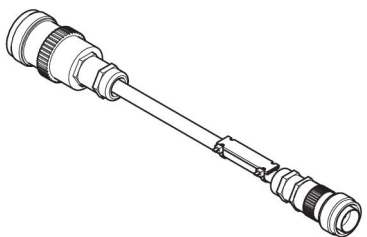
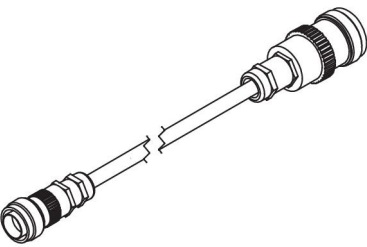
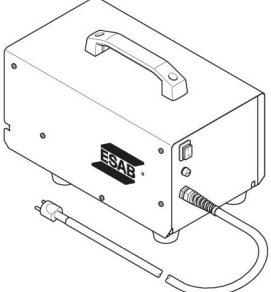
0460 910 880	5 m (16 ft)	
0460 910 881	15 m (49 ft)	
0460 910 882	25 m (82 ft)	
0460 910 883	35 m (115 ft)	
0460 910 884	50 m (164 ft)	
0460 910 885	75 m (246 ft)	
0460 910 886	100 m (328 ft)	

Control cable EAC 10 - digital power source and work piece voltage reference brush		
0446 146 880	5 m (16 ft)	
0446 146 881	15 m (49 ft)	
0446 146 882	25 m (82 ft)	
0446 146 883	35 m (115 ft)	
0446 146 884	50 m (164 ft)	
0446 146 885	75 m (246 ft)	
Control cable EAC 10 - ESAB analogue power source		
0449 500 880	15 m (49 ft)	
0449 500 881	25 m (82 ft)	
0449 500 882	35 m (115 ft)	
0449 500 883	50 m (164 ft)	
0449 500 884	75 m (246 ft)	
0449 500 885	100 m (328 ft)	
Interfejs źródła prądu spawania, for non-ESAB analogue SAW power source		
0446 180 880	115 V version	
0446 180 881	230 V version	
0462 062 001	USB Memory stick 2 Gb	

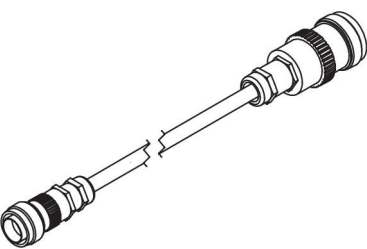
Welding power source interface		
Control cable EAC 10 - Welding power source interface		
0446 179 880	15 m (49 ft)	
0446 179 881	25 m (82 ft)	
0446 179 882	35 m (115 ft)	
0446 179 883	50 m (164 ft)	
0446 179 884	75 m (246 ft)	
0446 179 885	100 m (328 ft)	
Control cable for welding power source interface - general analogue controlled power source		

ACCESSORIES

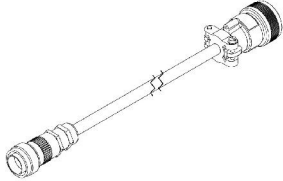
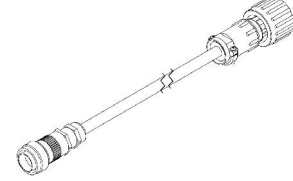
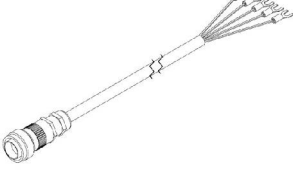
0446 157 880	<p>Cable with 14-pin MS3106 20-27PX plug Suitable for power sources:</p> <ul style="list-style-type: none"> • Lincoln Flextec 650/650x • Lincoln DC 600 • Lincoln DC 655 	
0446 156 880	<p>Control cable 14-pin, CPC type Suitable for power sources:</p> <ul style="list-style-type: none"> • Miller dimension 650, 652, 452 	
0446 178 880	<p>Control cable, terminal block Suitable for power sources:</p> <ul style="list-style-type: none"> • Miller SubArc DC 650, 800, 1000, 1250 • Lincoln DC 1000 	

CZĘŚCI EKSPLOATACYJNE

Rolki podające

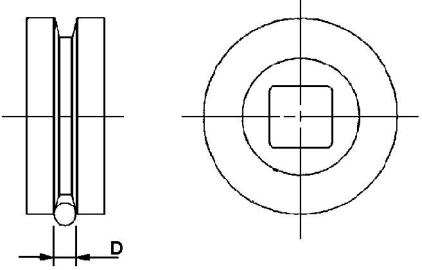
SAW		
Part no.	D (mm)	
0218 510 281	1.6	
0218 510 282	2.0	
0218 510 283	2.5	
0218 510 286	4.0	
0218 510 287	5.0	
0218 510 298	3.0–3.2	

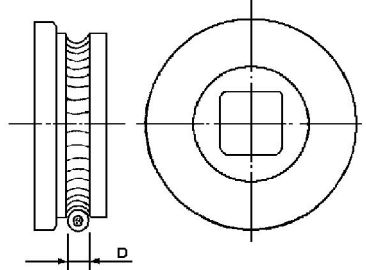
Grooved and knurled roller for tubular wire		
Part no.	D (mm)	
0146 024 880	0.8–1.6	
0146 024 881	2.0–4.0	

Rolki dociskowe

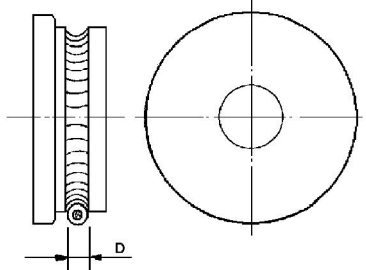
Pressure roller groved and knurled for tubular wire		
Part no.	D (mm)	
0146 025 880	0.8–1.6	
0146 025 881	2.0–4.0	
0146 025 882	5.0–7.0	

Walek krótki do rolki dociskowej

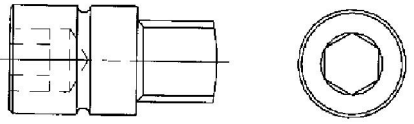
EWH 1000 tubular wire		
Part no.		
0212 901 101		